





Assembly View

## Installation Instructions

Challengers® Model CH6810  
Vortex

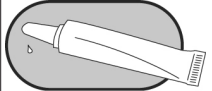
### Installation Preparation

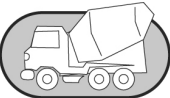
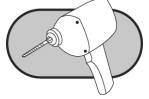
Recommended Crew: ..... Two (2) adults  
 Installation Time: ..... 2 man-hours  
 Concrete Required: ..... 0.13 cubic yard (0,10 cubic meters)  
 Use Zone: ..... Refer to Master Layout Drawing  
 User Group Age (years): ..... ASTM/CSA: 5-12, EN: 2-14

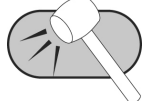
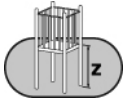
ICON KEY			
	Fully Tighten Hardware		Add 1 Drop of Thread Locking Adhesive
	Do <b>Not</b> Fully Tighten Hardware		Pour Concrete
	Drill		Dig Footing Holes
	Hammer		Critical Fall Height

# Installation Instructions

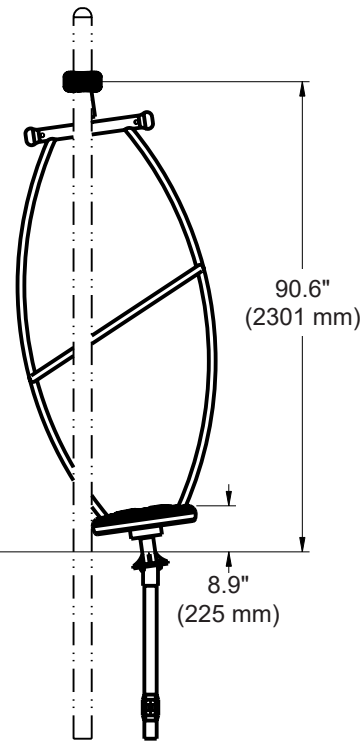
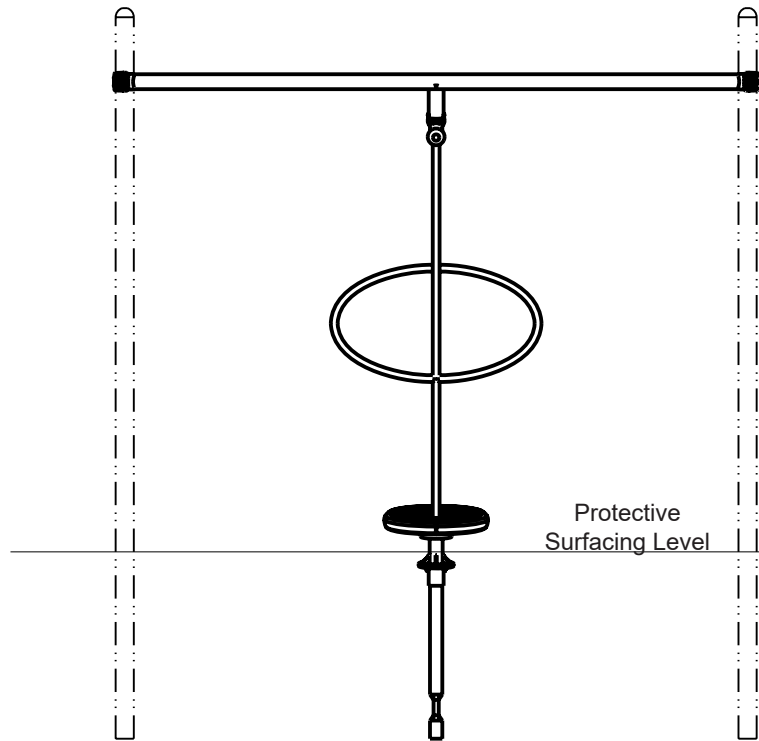
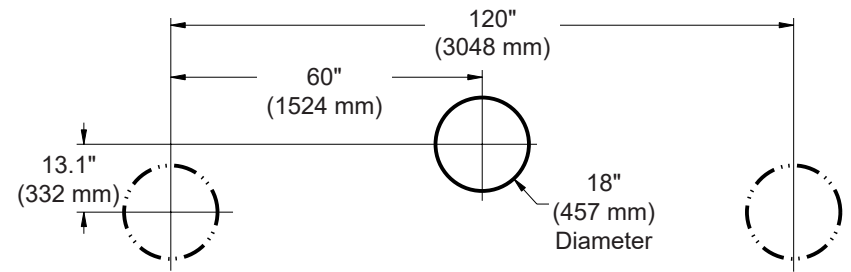
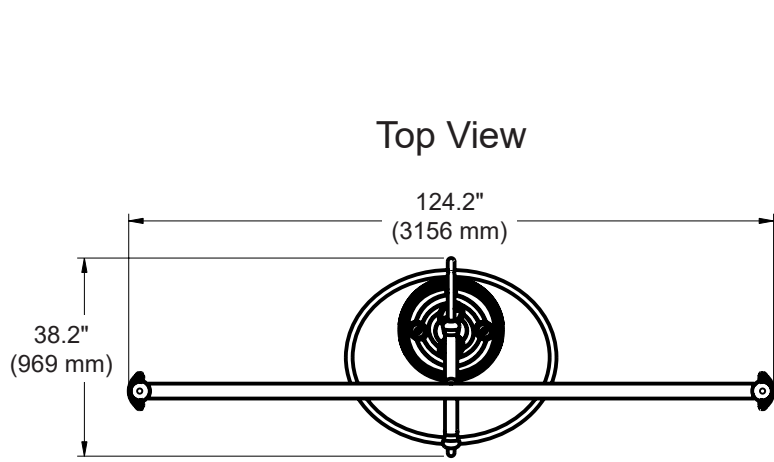

Step 3

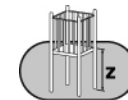

8.9"  
225 mm

Elevation Views

# Installation Instructions

Follow the details in alphabetical order. For clarification, each detail references the step description. The step descriptions start on page 7.

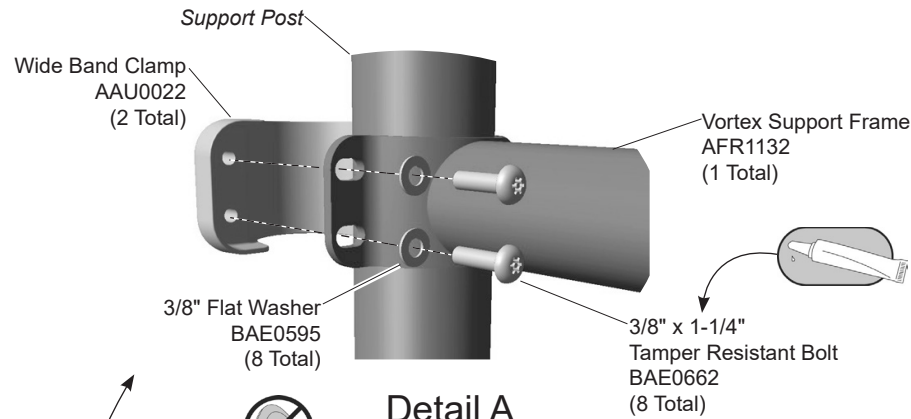

## Detail A Step 4

*Attach the support frame to the support posts.*

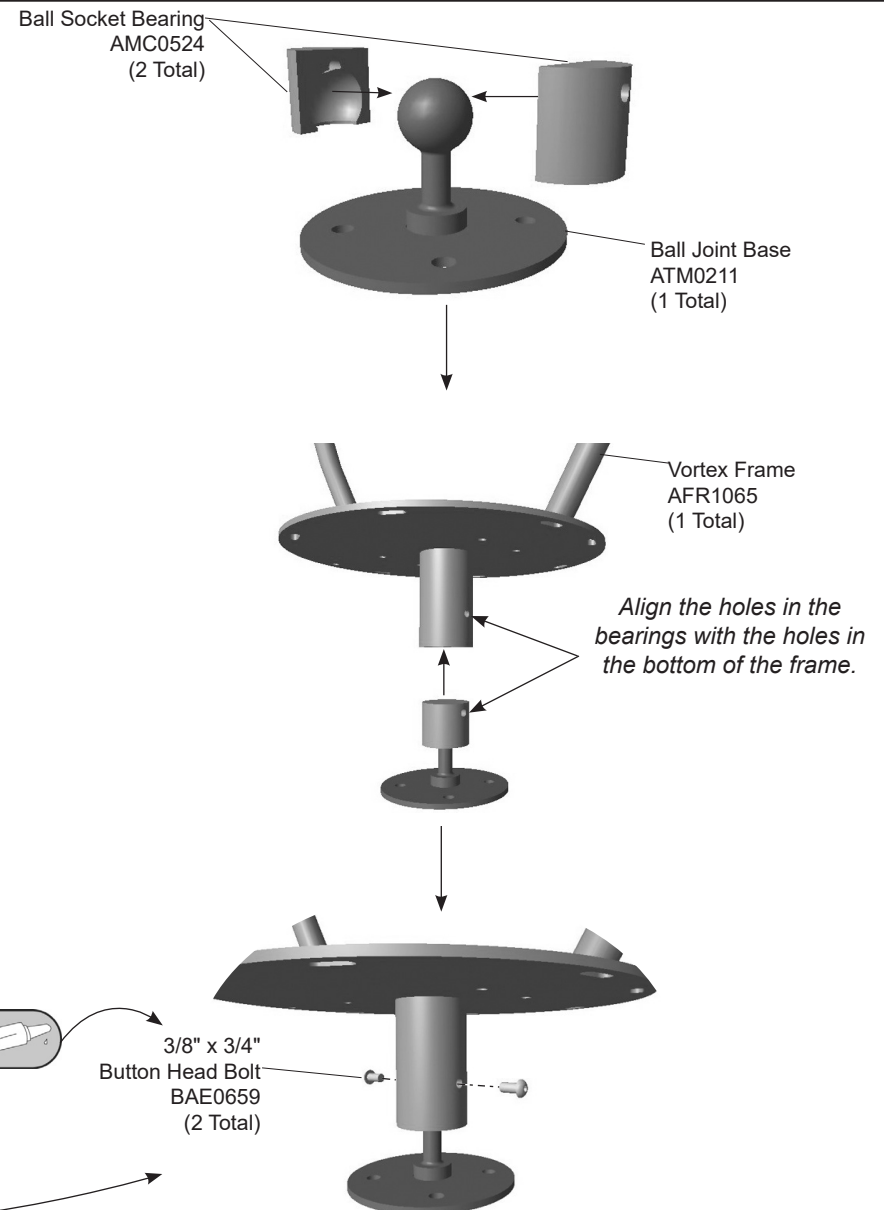
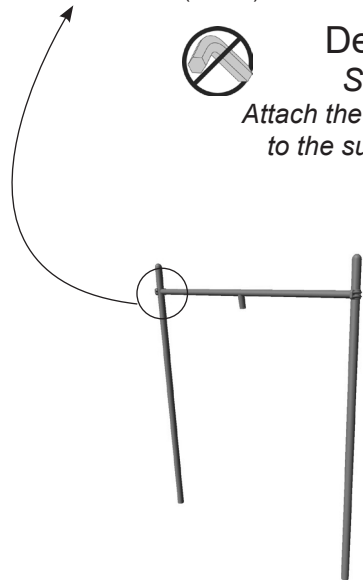

## Detail B Step 5

*Attach the bearing assembly to the Vortex frame.*



# Installation Instructions

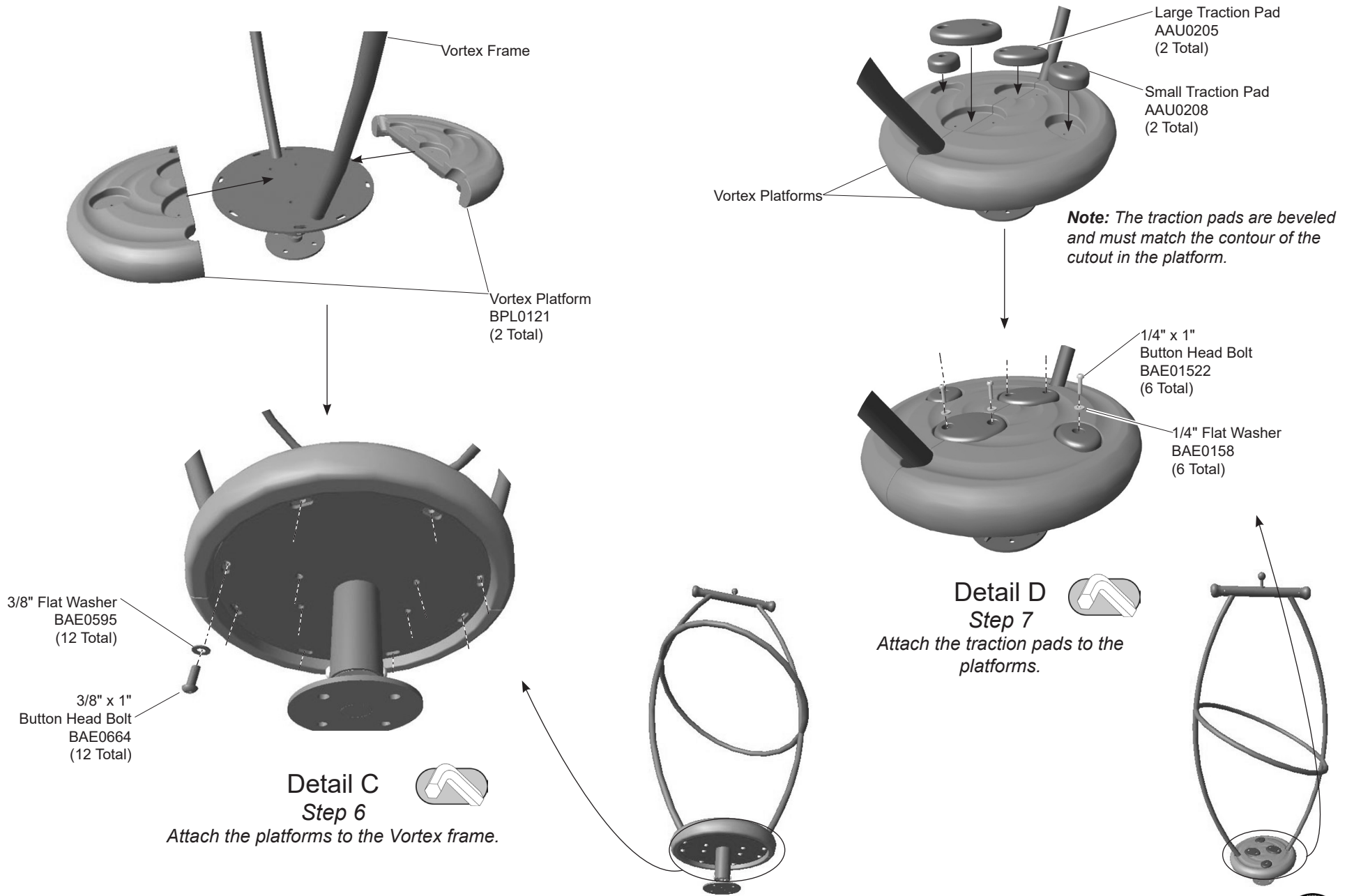

# Installation Instructions

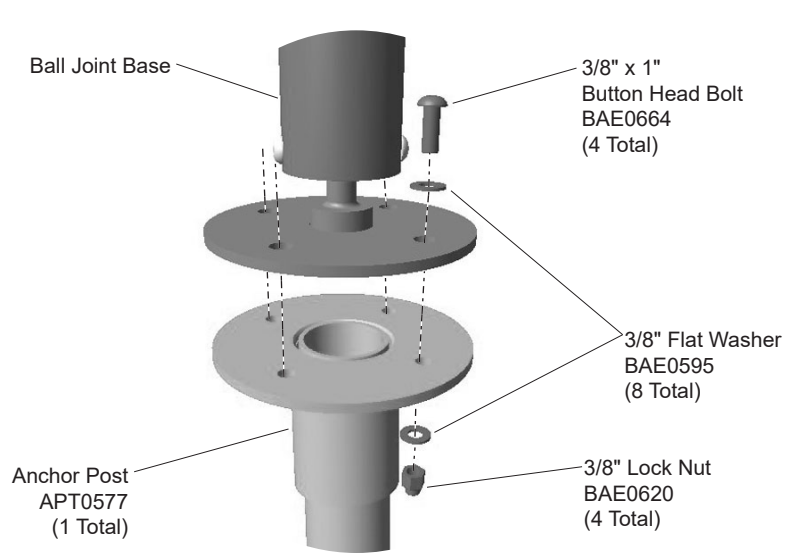

## Detail E Step 8

Attach the anchor post to the ball joint base.

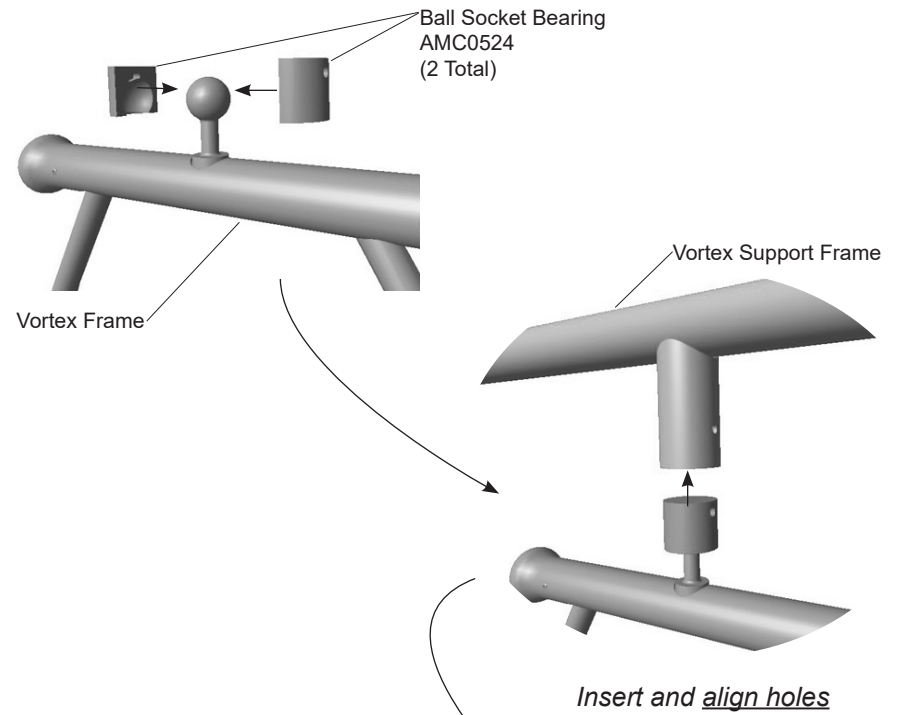

Insert and align holes

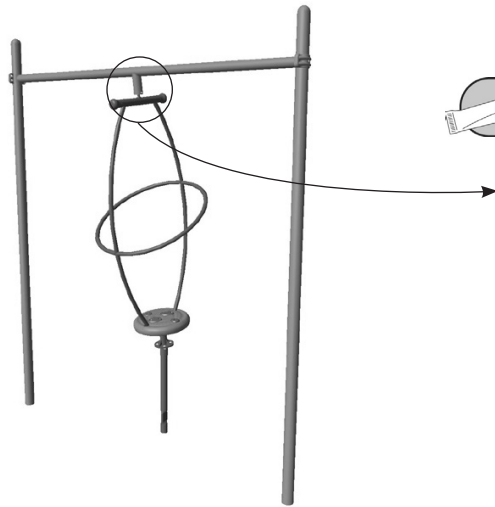
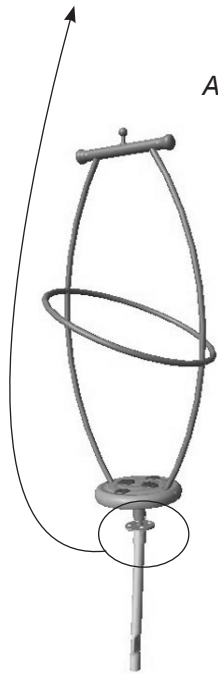

3/8" x 3/4"  
Button Head Bolt  
BAE0659  
(2 Total)



## Detail F Step 9

Attach the Vortex frame to the support frame.

# Installation Instructions

---



Step 10

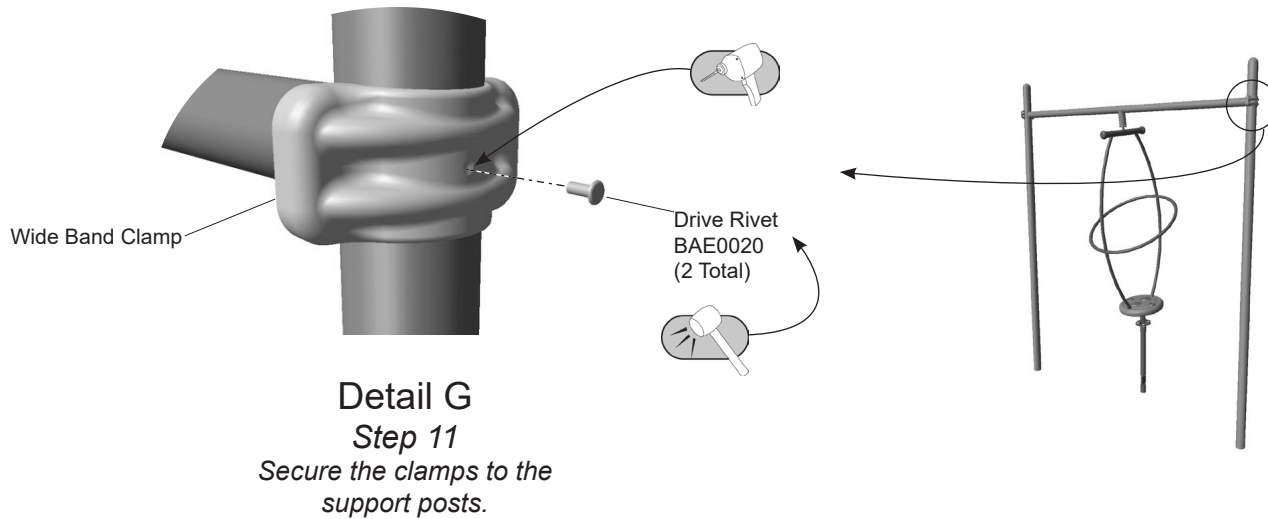

# Installation Instructions

---

**Notes Before You Begin:** Do not over tighten bolts during assembly, only snug tighten them until assembly is complete.

**Carefully read and understand these installation instructions before you begin.**

**Step 1:** Before attempting to assemble your equipment, please review all installation information carefully. Should you experience any difficulty during the installation process, please call us at the phone number shown on the last page of these instructions.

**Step 2:** Separate and identify all components and hardware.

**Step 3:** Excavate footings as shown in the **Support Post Footing Details**. Refer to the support post diagram and footings notes included in the Challenger Guidelines at the beginning of the printed instruction booklet. *(If viewing on the CD refer to ZZCHGUID.)* When fully tightening the connections, follow the recommended **Torque Specifications:**

*Bolts and nuts* - Snug tighten and then tighten an additional one half turn.

**Step 4:** Attach the support frame to the support posts. See **Detail A**. Position the support frame between the support posts at the height indicated in the **Elevation View**, apply a drop of thread locking adhesive to the bolt threads, and attach as shown.

**Step 5:** Attach the bearing assembly to the Vortex frame. See **Detail B**. Close the ball socket bearings around the top of the ball joint base and insert the base into the bottom of the spinner frame and align the holes in the socket bearings with those in the frame. Apply a drop of thread locking adhesive to the bolt threads and attach as shown. Fully tighten the connections according to the tightening torque specifications.

**Step 6:** Attach the platforms to the Vortex frame. See **Detail C**. Position the platforms on the frame and attach as shown. Fully tighten the connections according to the tightening torque specifications.

**Step 7:** Attach the traction pads to the platforms. See **Detail D**. Insert each traction pad into it's corresponding indentation in the platform and attach as shown. Fully tighten the connections according to the tightening torque specifications.

**Note:** *the traction pads are beveled and must match the contour of the cutout in the platform.*

**Step 8:** Attach the anchor post to the bearing unit. See **Detail E**. Position the top of the anchor post against the bottom of the bearing unit and attach as shown. Fully tighten the connections according to the tightening torque specifications.

**Step 9:** Attach the Vortex assembly to the support frame. See **Detail F**. Place the socket bearings around the ball on the top of the Vortex frame assembly. With adequate manpower, lift the assembly up and into the support frame and align the holes in the socket bearings with those in the frame. Apply a drop of thread locking adhesive to the bolt threads and attach as shown. Fully tighten the connections according to the tightening torque specifications.

## Final Details.

**Step 10:** Plumb and level the component. Tighten **all** fasteners. Fully tighten all fasteners according to tightening torque specifications. Block and brace for concrete. Pour concrete after all equipment has been assembled. Allow 72 hours for concrete to completely cure.

**Step 11:** Install drive rivets. See **Detail G**. After the equipment assembly is complete, install a drive rivet in each clamp to permanently secure it to the support post. Using a 1/4" drill bit, drill through the clamp and support post. Insert the drive rivet into drilled hole until the head of the rivet is against the surface of the clamp. Using a hammer, pound the pin of the rivet until it is flush with the surface of the rivet head.

**Note:** This step should be executed after structure has been assembled and properly footed.

**Step 12:** For areas complying with ASTM standard F1487 or the CSA Z-614, apply the age appropriate label to the side panel at eye level.

## CH6810 - VORTEX

PART NO.	DESCRIPTION	QTY.
AAU0022	CLAMP - 3-1/2" W.I.D.E ALUMINUM	2
AAU0205	4.88" TRACTION PAD	2
AAU0208	3.38" TRACTION PAD	2
AFR1065	FRAME - 87.27" x 37.16" x 40.59"	1
AFR1132	FRAME - VORTEX (CH)	1
AMC0524	BEARING - BALL SOCKET	4
APT0577	POST - VORTEX	1
ATM0211	BALL JOINT - SURFACE MOUNT	1
BAD0085	THREAD LOCKING ADHESIVE	1
BAE0020	RIVET - 1/4" x 11/16" DRIVE	2
BAE01522	BOLT - 1/4"-20 x 1" BUTTON HEAD - SS	6
BAE0158	WASHER - 1/4" SAE FLAT	6
BAE0595	WASHER - 3/8" SAE FLAT	28
BAE0620	NUT - 3/8"-16 LOCK w/NYLON CAP	4
BAE0659	BOLT - 3/8"-16 x 3/4" BUTTON HEAD - SS	4
BAE0662	BOLT - 3/8"-16 x 1-1/4" TMPR RESISTANT w/TORX DRV	8
BAE0664	BOLT - 3/8"-16 x 1" BUTTON HEAD - SS	16
BPL0121	VORTEX PLATFORM	2
ALB0025	LABEL - AGE APPROPRIATE SHEET	1

 **PLAYWORLD**  
The world needs play.<sup>®</sup>

For Customer Service, Call  
**800-233-8404** or  
**570-522-9800** OUTSIDE U.S.  
1000 Buffalo Road • Lewisburg, PA 17837  
[www.playworldsystems.com](http://www.playworldsystems.com)